

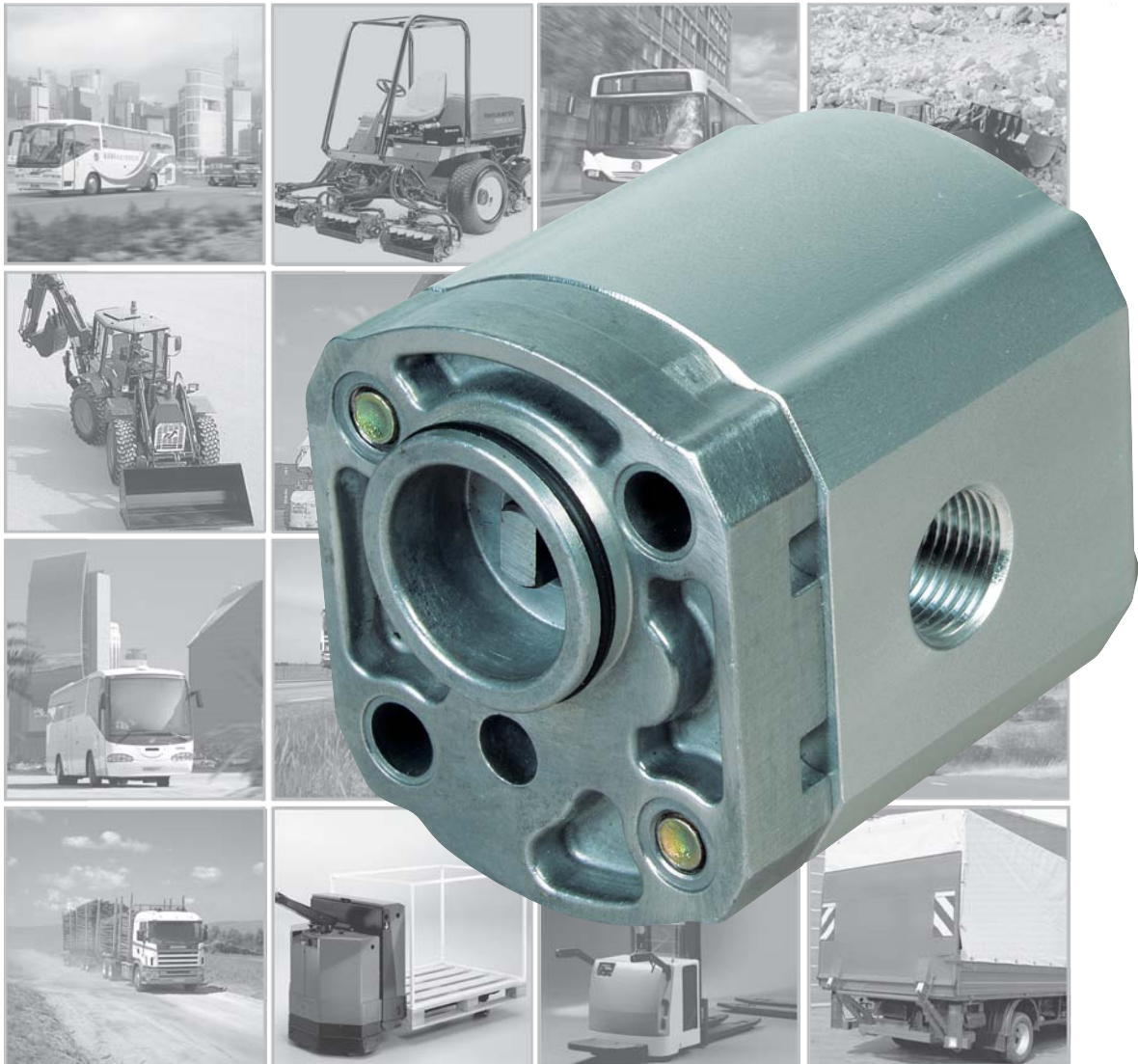

HIGH PRESSURE GEAR PUMP W300

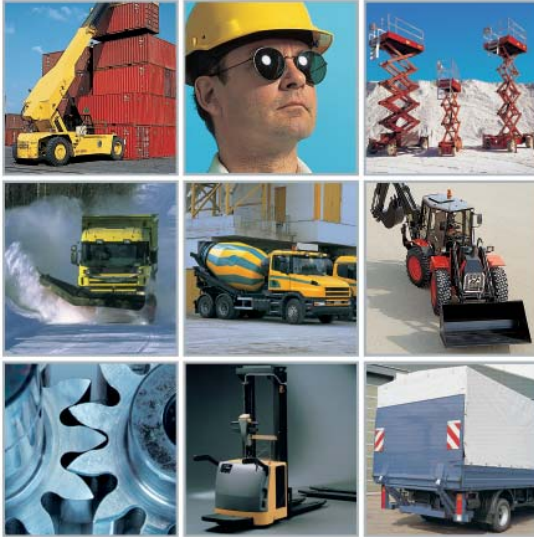



THE POWER OF THE W300 B SERIES

Concentric is one of the world's leading manufacturers of hydraulic pumps. Our focus on important strategic markets such as trucks, construction equipment and materials handling has brought results: a series of high-performance hydraulic pumps. The W300 series builds on the versatile technical platform represented by the W series.

W300 High Pressure Gear Pumps are optimized for demanding work, with harsh weather conditions, rugged operations and long service intervals. The W300 series is a range of cost-efficient small pumps for all applications in which the customer's demands for quality and accessibility are particularly high.

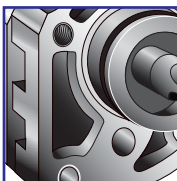

FLANGE CODE 20, 22, 23

4-6

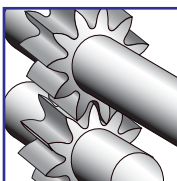

EFFICIENCIES

7

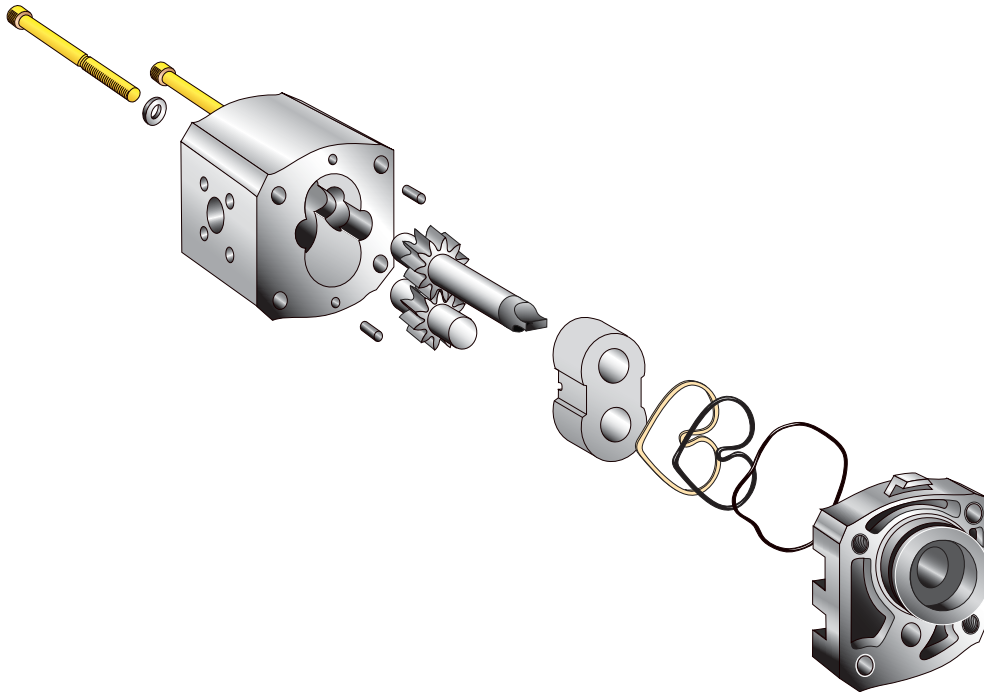

Model code example for a single pump

WP 03 B 1 B 008 R 20 MA 124 N
 ① ② ③ ④ ⑤ ⑥ ⑦ ⑧ ⑨ ⑩ ⑪

- | | |
|------------------------------|---------------------|
| ① = Type | ⑦ = Rotation |
| ② = Series | ⑧ = Mounting flange |
| ③ = Design revision | ⑨ = Drive shaft |
| ④ = # of sections | ⑩ = Portings |
| ⑤ = Seal material | ⑪ = Valve options |
| ⑥ = Displacement per section | |

W300 DESCRIPTION

The W300 pumps come in single configuration and have a two piece modular design. All, mounting flange, and rear cover are manufactured of high strength aluminium alloy.

For optimum strength, gears and shafts are precision machined as a one-piece-part. The 11-tooth gear geometry has been optimized for low noise level and low pressure pulsation.

All shaft bearing surfaces are continually cooled and lubricated by a controlled flow of fresh oil. This permits operation across a wide speed range at very high loads. Extra large slide bearings help guarantee a long service life.

A wide range of mounting flanges and port sizes are available to meet all international standards.

General data

Displacement V 0.8 ... 5.7cm³
 Speed n 800 ... 6000 rpm
 Pressure rated pressure p_1 up to 230 bar
 intermittent pressure p_{II} up to 255 bar
 Operating temperatures t up to 90°C
 Average volumetric efficiency 97%
 The maximum values for n , p_1 and t for a given pump specification may be applied sim-ultaneously.

Options

- Rectangular flanges, through bolt model.
- Tapered shaft with key, tang shaft.
- Thread ports of flange ports.
- Clockwise or anti-clockwise rotation.
- Integrated valve features.

PERFORMANCE DATA

Operating pressure range

Inlet port: continuous, minimum -0,20 bar
 intermittent, minimum -0,35 bar
 maximum +2,00 bar

Outlet port (See tables on pages 4-6)

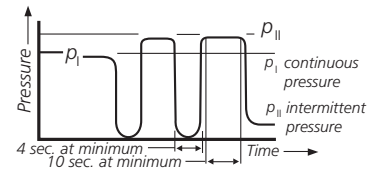

Product has been tested to 500,000 cycles at p_{II} . Pressure p_{II} is permitted at maxi. 10 sec loaded following 4 sec minimum unloaded. Above represents performance which can be expected from units incorporating flange flange port styles.

Speed range

Minimum speed for all pump sizes depends on the pump model in question and can be identified from Tables below onwards for respective models.

Maximum speed for single pumps depends on the pump model in question and can be identified from Tables onwards for respective models.

Noise performance data according to DIN 45 635.

Typical levels for pump type W3B1-2,5 at 160 bar using mineral oil with viscosity of 40mm²/s and at temperature of 50° C at different speeds:

1500 min ⁻¹	2300min ⁻¹	3000min ⁻¹
52 dB(A)	56 dB(A)	57 dB(A)

Hydraulic fluids. The use of HL-or HLP-hydraulic oil according to DIN 51 524 is recommended.

The permissible viscosity for all W3B pumps ranges from 800 to 12 mm²/s.

The permissible cold start viscosity is 2000 mm²/s.

We recommend to contact Concentric before using fire resistant or bio-degradable fluids.

Temperature range

Amb. temperature,	mini.-25° C;
	maxi.+80° C
Fluid temperature,	
continuous operation,	maxi.+80° C
short term operation,	maxi.+90° C

Please note

Viscosities -when operating at above temperature limits-have to remain within the range specified under "Hydraulic Fluids".

Fluid cleanliness

Fluid cleanliness according to ISO 4406/1986 Code 18/14 or better is required in order to assure the pump's high level of efficiency in the long term.

Drive arrangement

Flexible couplings are preferred for direct drives. Please contact Concentric for indirect drive requirements.

Mounting position

As required.

Symbol

Single pump.

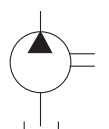



FLANGE CODE 20

All shaft bearings are continually cooled and lubricated by a controlled flow of fresh oil. This enables operation across a wide speed range at very high loads. The largesized slide bearings support the pump's long-life condition. A wide range of mounting flanges and

port sizes are available to meet European and international standards. W300 pumps may also be supplied with threaded ports in the rear cover (Rear cover's shape is prepared for this option). This option can simplify installation where space is limited.

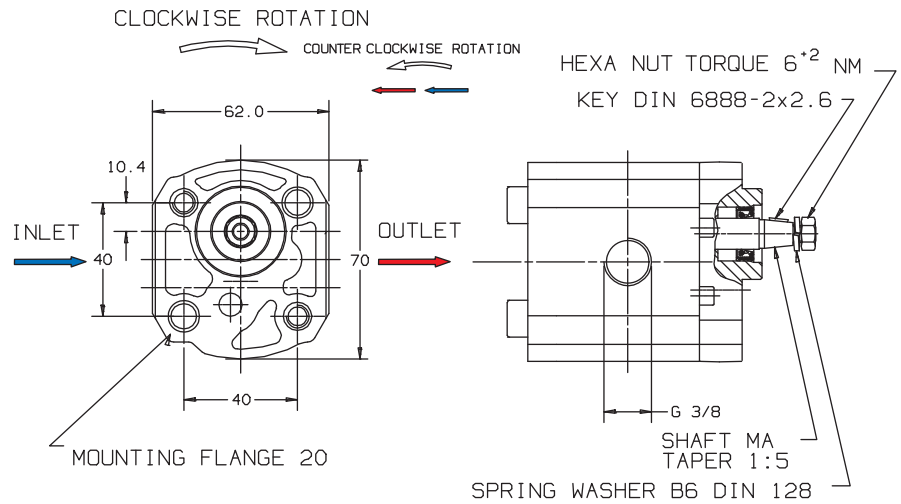
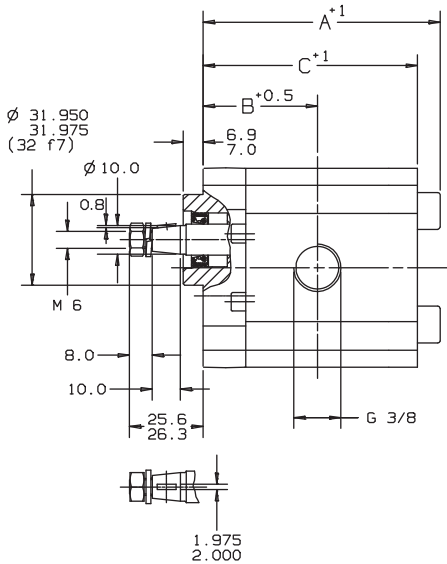

Model code example for a single pump

WP 03 B 1 B 008 R 20 MA 124 N
 ① ② ③ ④ ⑤ ⑥ ⑦ ⑧ ⑨ ⑩ ⑪

- ① = Type WP - Pump
- ② = Series 03 - 300
- ③ = Design revision B - 2 nd release
- ④ = # of sections 1 - Single
- ⑤ = Seal material B - Buna
- ⑥ = Displacement per section (See table below)
- ⑦ = Rotation
R - Clockwise
L - Counter clockwise
- ⑧ = Mounting flange 20
- ⑨ = Drive shaft MA
- ⑩ = Portings
124 - G3/8" + G3/8" BSPP
166 - M18 x 1,5 + M14 x 1,5
- ⑪ = Valve options N - None

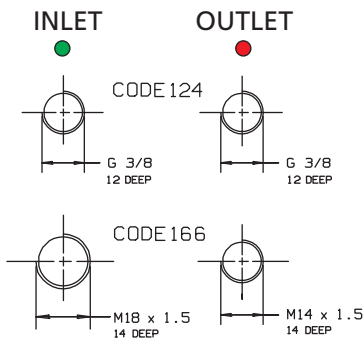

At CCW rotation inlet and outlet are reversed.

Code Displ.	Rated pressure P _I [bar]	Intermitt. P _{II} [bar]	Maxi. speed [min ⁻¹]	Mini. speed [min ⁻¹]	Dimensions			Weight (approx.) kg
					A [mm]	B [mm]	C [mm]	
008 - 0,8cc	230	255	6000	1200	68,1	32,6	60,1	0,70
012 - 1,2cc	230	255	6000	1100	69,8	33,4	61,8	0,72
016 - 1,6cc	230	255	6000	1100	71,5	34,2	63,5	0,74
020 - 2,0cc	230	255	6000	1000	73,2	35,1	65,2	0,77
025 - 2,5cc	230	255	5000	1000	75,3	35,9	67,3	0,80
032 - 3,2cc	230	255	5000	1000	78,2	37,6	70,2	0,83
038 - 3,8cc	210	230	4500	850	80,8	38,9	72,8	0,86
043 - 4,3cc	190	210	4500	850	82,9	40,0	74,9	0,89
048 - 4,8cc	170	187	4200	800	85,0	41,0	77,0	0,91
057 - 5,7cc	145	160	3800	800	98,8	42,9	80,8	0,96

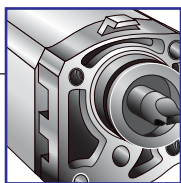

FLANGE CODE 22

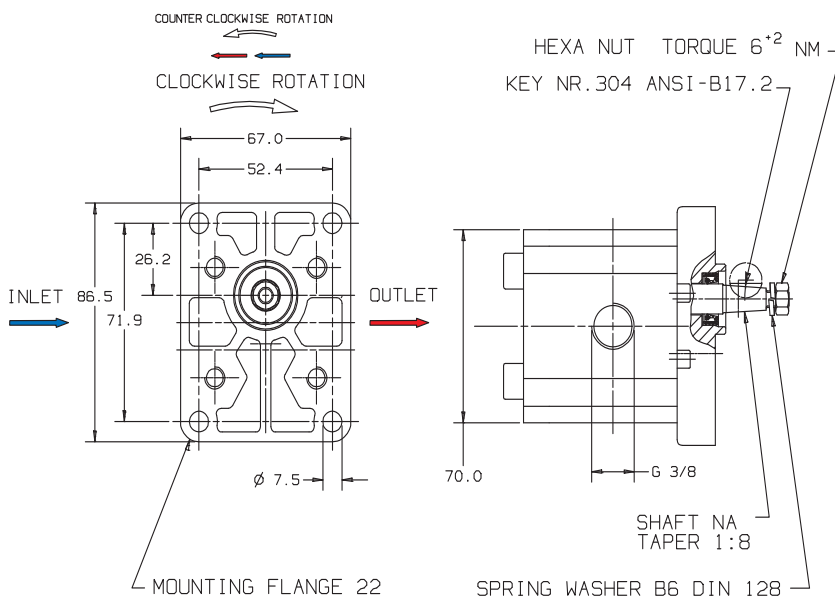
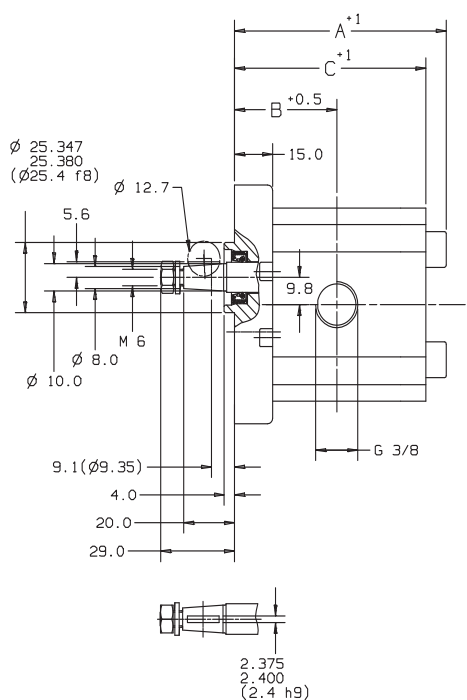

Model code example for a single pump

WP 03 B 1 B 008 R 22 NA 124 N
 ① ② ③ ④ ⑤ ⑥ ⑦ ⑧ ⑨ ⑩ ⑪

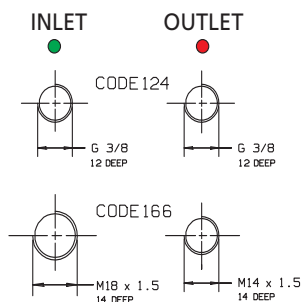

- ① = Type WP - Pump
- ② = Series 03 - 300
- ③ = Design revision B - 2 nd release
- ④ = # of sections 1 - Single
- ⑤ = Seal material B - Buna
- ⑥ = Displacement per section (See table below)
- ⑦ = Rotation
R - Clockwise
L - Counter clockwise
- ⑧ = Mounting flange 22
- ⑨ = Drive shaft NA
- ⑩ = Portings
124 - G3/8" + G3/8" BSPP
166 - M18 x 1,5 + M14 x 1,5
- ⑪ = Valve options N - None

At CCW rotation inlet and outlet are reversed.

Code Displ.	Rated pressure P_I [bar]	Intermitt. P_{II} [bar]	Maxi. speed [min^{-1}]	Mini. speed [min^{-1}]	Dimensions			Weight (approx.) kg
					A [mm]	B [mm]	C [mm]	
008 - 0,8cc	230	255	6000	1200	68,1	32,6	60,1	0,70
012 - 1,2cc	230	255	6000	1100	69,8	33,4	61,8	0,72
016 - 1,6cc	230	255	6000	1100	71,5	34,2	63,5	0,74
020 - 2,0cc	230	255	6000	1000	73,2	35,1	65,2	0,77
025 - 2,5cc	230	255	5000	1000	75,3	35,9	67,3	0,80
032 - 3,2cc	230	255	5000	1000	78,2	37,6	70,2	0,83
038 - 3,8cc	210	230	4500	850	80,8	38,9	72,8	0,86
043 - 4,3cc	190	210	4500	850	82,9	40,0	74,9	0,89
048 - 4,8cc	170	187	4200	800	85,0	41,0	77,0	0,91
057 - 5,7cc	145	160	3800	800	98,8	42,9	80,8	0,96



FLANGE CODE 23

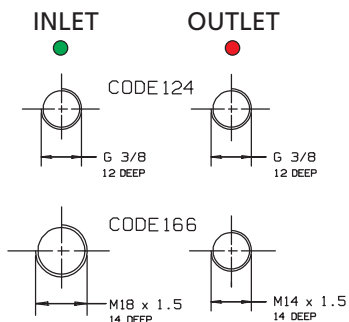
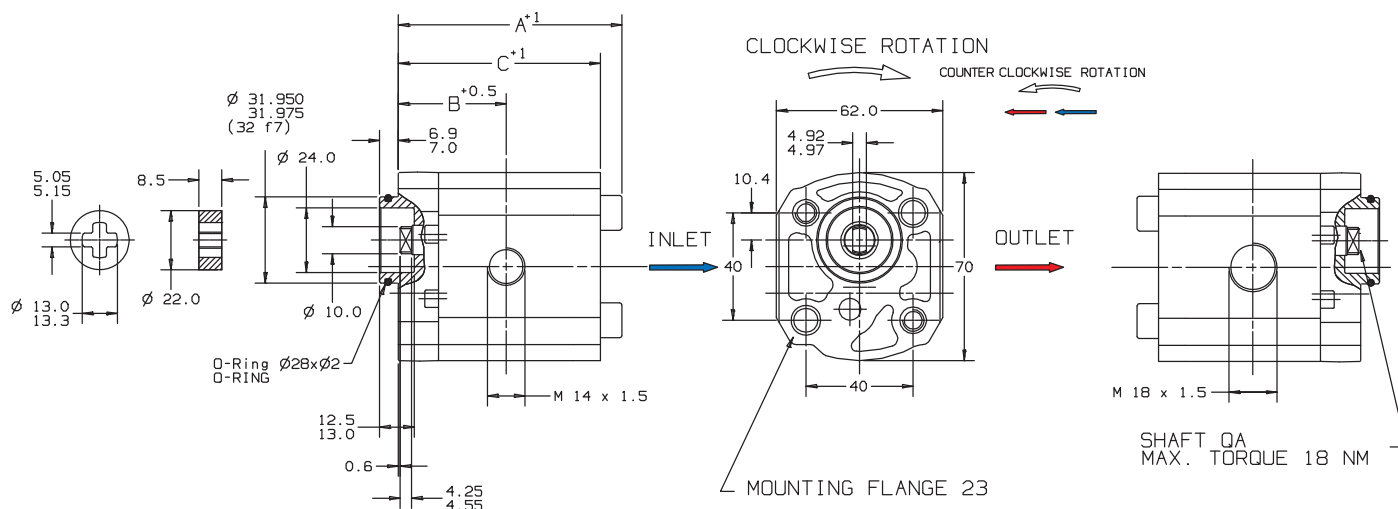

Model code example for a single pump

WP 03 B 1 B 008 R 23 QA 124 N
 ① ② ③ ④ ⑤ ⑥ ⑦ ⑧ ⑨ ⑩ ⑪

- ① = Type WP - Pump
- ② = Series 03 - 300
- ③ = Design revision B - 2 nd release
- ④ = # of sections 1 - Single
- ⑤ = Seal material B - Buna
- ⑥ = Displacement per section (See table below)
- ⑦ = Rotation
R - Clockwise
L - Counter clockwise
- ⑧ = Mounting flange 23
- ⑨ = Drive shaft QA
- ⑩ = Portings
124 - G3/8" + G3/8" BSPP
166 - M18 x 1,5 + M14 x 1,5
- ⑪ = Valve options N - None

At CCW rotation inlet and outlet are reversed.

Code Displ.	Rated pressure P_I [bar]	Intermitt. P_{II} [bar]	Maxi. speed [min ⁻¹]	Mini. speed [min ⁻¹]	Dimensions			Weight (approx.) kg
					A [mm]	B [mm]	C [mm]	
008 - 0,8cc	230	255	6000	1200	68,1	32,6	60,1	0,68
012 - 1,2cc	230	255	6000	1100	69,8	33,4	61,8	0,70
016 - 1,6cc	230	255	6000	1100	71,5	34,2	63,5	0,72
020 - 2,0cc	230	255	6000	1000	73,2	35,1	65,2	0,75
025 - 2,5cc	230	255	5000	1000	75,3	35,9	67,3	0,78
032 - 3,2cc	230	255	5000	1000	78,2	37,6	70,2	0,81
038 - 3,8cc	210	230	4500	850	80,8	38,9	72,8	0,84
043 - 4,3cc	190	210	4500	850	82,9	40,0	74,9	0,87
048 - 4,8cc	170	187	4200	800	85,0	41,0	77,0	0,89
057 - 5,7cc	145	160	3800	800	98,8	42,9	80,8	0,94

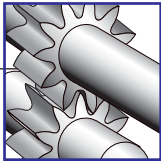

EFFICIENCIES, TOTAL, MECHANICAL, VOLUMETRIC

OVERALL EFFICIENCY W3B1-1.2-*-N-N**
AVERAGE ± 3% AT 42°C, 32 cSt.

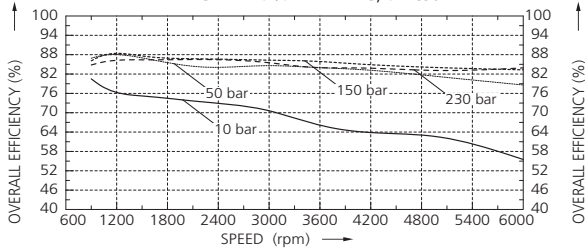

MECHANICAL EFFICIENCY W3B1-1.2-*-N-N**
AVERAGE ± 3% AT 42°C, 32 cSt.

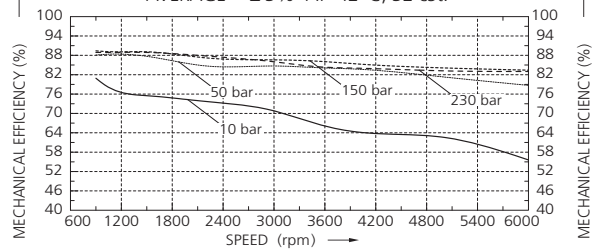

VOLUMETRIC EFFICIENCY W3B1-1.2-*-N-N**
AVERAGE ± 3% AT 42°C, 32 cSt.

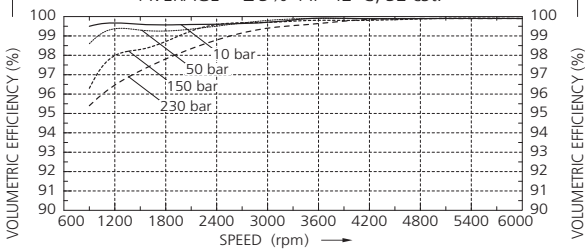

OVERALL EFFICIENCY W3B1-3.2-*-N-N**
AVERAGE ± 3% AT 42°C, 32 cSt.

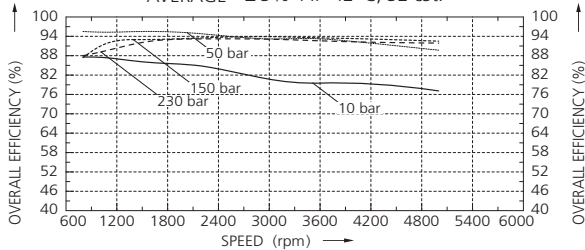

MECHANICAL EFFICIENCY W3B1-3.2-*-N-N**
AVERAGE ± 3% AT 42°C, 32 cSt.

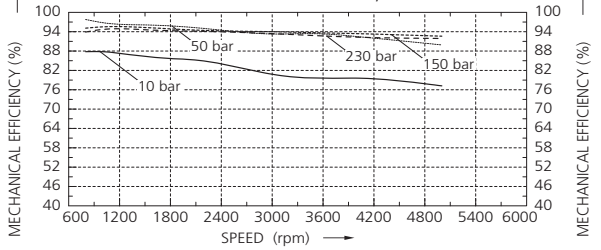

VOLUMETRIC EFFICIENCY W3B1-3.2-*-N-N**
AVERAGE ± 3% AT 42°C, 32 cSt.

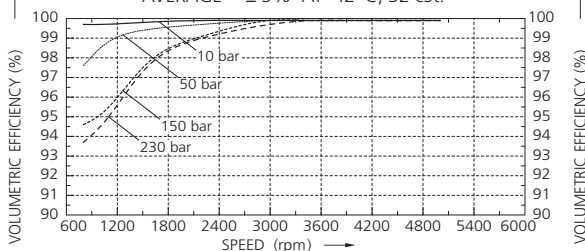

OVERALL EFFICIENCY W3B1-4.8-*-N-N**
AVERAGE ± 3% AT 42°C, 32 cSt.

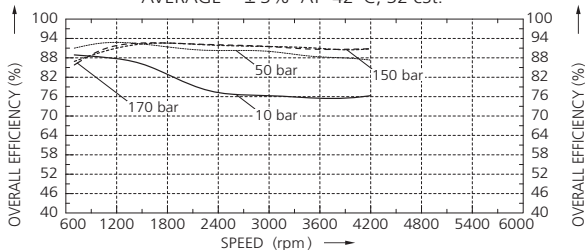

MECHANICAL EFFICIENCY W3B1-4.8-*-N-N**
AVERAGE ± 3% AT 42°C, 32 cSt.

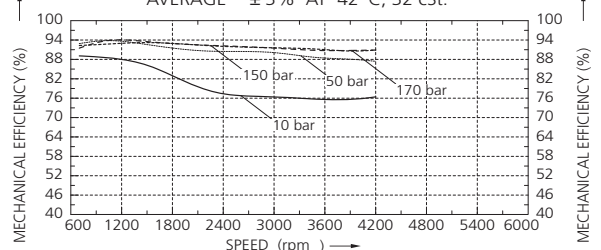

VOLUMETRIC EFFICIENCY W3B1-4.8-*-N-N**
AVERAGE ± 3% AT 42°C, 32 cSt.

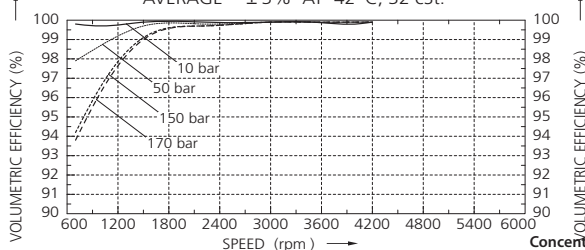

PRODUCT RANGE

HE Powerpacks

12/24/48 VDC 0.3 – 4.5 kW and
0.75 – 3 kW AC modular power packs

HE Box Powerpacks

12/24/48 VDC modular powerpacks
in weatherproof boxes

Pressure Switches

5 - 350 bar, connecting/disconnecting

W100 Hydraulic pumps

0,5 - 2,0 cc 227 bar

W300 Hydraulic pumps

0,8 – 5,7 cc 230 bar

W600 Hydraulic pumps / motors

3 – 12 cc 276 bar

W900 Hydraulic pumps / motors

5 – 31 cc/section 276 bar

Calma The new quiet pumps

6,2 - 23,7 cc/section 250 bar

WQ900 The quiet pumps

5 - 23 cc/section 230 bar

WP900X Hydraulic pumps

16 - 31 cc/section 276 bar

W1500 Hydraulic pumps / motors

19 - 50 cc/section 276 bar

F12 FERRA Heavy duty pumps

16 - 41 cc/section 276 bar

F15 FERRA Heavy duty pumps

19 - 50 cc/section 276 bar

F20/F30 (LS) Hydraulic pumps / motors

23 – 161 cc/section 276 bar

GPA Internal Gear pumps

1,7 – 63 cc/section 100 bar

GC Hydraulic pumps / motors

1,06 – 11,65 cc/section 276 bar

D Hydraulic pumps

3,8 – 22,9 cc/section 207 bar

H Hydraulic pumps

9,8 – 39,4 cc/section 207 bar

II-Stage Hydraulic pumps

4,2 – 22,8 cc/section 276 bar

Rotary Flow Dividers

3,8 – 13,3 cc/section 300 bar

Transmission pumps

www.concentricAB.com



Concentric Rockford Corp.
2222 15th Street
ROCKFORD, IL 61104
USA

Tel: +1-815 398 4400

Fax: +1-815 398 5977

E-mail: info.hydraulics.us@concentricAB.com

Concentric Hof GmbH
Postfach 1507
D-95014 HOF
Germany

Tel: +49-9281 895-0

Fax: +49-9281 87133

E-mail: info.hydraulics.eu@concentricAB.com

Concentric Skanes AB
Box 95
SE-280 40 SK. FAGERHULT
Sweden

Tel: +46-433 32400

Fax: +46-433 30546

E-mail: info.hydraulics.eu@concentricAB.com

Concentric Suzhou Co. Ltd.
47 Dongjing Industrial Park
9 Dong Fu Lu
SIP, Suzhou
Jiangsu

China 215123

Tel +86 512 8717 5100

Fax +86 512 8717 5101

info.chsh@concentricAB.com



Concentric is an innovator in flow control and fluid power, supplying proprietary systems and components for trucks, buses and industrial vehicles, worldwide. With 1,156 employees and yearly sales exceeding 1,977 million Swedish Kronor, Concentric AB is listed on the Stockholm Stock Exchange (www.concentricAB.com).

Concentric will not accept responsibility for any catalog errors and reserves the right to modify its products without prior notice. This also applies to products already ordered, provided that such modifications can be made without affecting technical specifications. All trademarks in this material are properties of their respective owners.